

Installation Note

Extended Frequency Range Upgrade Kits

For PNA Series RF Network Analyzers (E8356A and E8357A)

Network Analyzer Model Number	Upgrade Kit Part Number	Frequency Extension
E8356A	E8356-60104	3 GHz to 6 GHz
E8356A	E8356-60105	3 GHz to 9 GHz
E8357A	E8357-60101	6 GHz to 9 GHz



Agilent Technologies

Agilent Part Number: E8356-90052

Printed in USA November 2001

Notice.

The information contained in this document is subject to change without notice.

Agilent Technologies makes no warranty of any kind with regard to this material, including but not limited to, the implied warranties of merchantability and fitness for a particular purpose. Agilent shall not be liable for errors contained herein or for incidental or consequential damages in connection with the furnishing, performance, or use of this material.

About the Upgrade Kits

Products affected.	E8356A and E8357A; all options (See NOTE below.)
Installation to be performed by	Agilent service center, personnel qualified by Agilent, or customer
Estimated installation time	E8356A–30 minutes E8357A–5 minutes
Estimated verification time	5 minutes
Estimated calibration adjustment time.	45 minutes

NOTE If the Time Domain option, Option 010, is already installed on your analyzer, you will need a new license key for that option to function after installation of the frequency upgrade. Contact Agilent for this new license key.

If you need assistance, refer to [“Getting Assistance from Agilent” on page 5](#).

Description of the Upgrades

These upgrade kits are used to extend the frequency range of the:

- E8356A PNA RF network analyzer from 3 GHz to either 6 GHz or 9 GHz
- E8357A PNA RF network analyzer from 6 GHz to 9 GHz

Items Included in the Upgrade Kits

The following three tables list the parts included in the upgrade kits for the E8356A and E8357A network analyzers. Check the contents of your kit against the appropriate list. If any item is missing or damaged, contact Agilent Technologies. Refer to [“Getting Assistance from Agilent” on page 5](#).

Table 1 Option 006 Upgrade Kit to Extend the E8356A to 6 GHz (E8356-60104)

Description	Qty	Part Number
Installation note (this document)	1	E8356-90052
License key certificate	1	5964-5136
Model number nameplate	1	E8357-80001
A12 source assembly	1	E8356-60012

Table 2 Option 009 Upgrade Kit to Extend the E8356A to 9 GHz (E8356-60105)

Description	Qty	Part Number
Installation note (this document)	1	E8356-90052
License key certificate	1	5964-5136
Model number nameplate	1	E8358-80001
A12 source assembly	1	E8356-60012

Table 3 Option 009 Upgrade Kit to Extend the E8357A to 9 GHz (E8357-60101)

Description	Qty	Part Number
Installation note (this document)	1	E8356-90052
License key certificate	1	5964-5136
Model number nameplate	1	E8358-80001

Getting Assistance from Agilent

By internet, phone, or fax, get assistance with all your test and measurement needs.

Table 4 Contacting Agilent

Online assistance: www.agilent.com/find/assist		
United States <i>(tel)</i> 1 800 452 4844	Latin America <i>(tel)</i> (305) 269 7500 <i>(fax)</i> (305) 269 7599	Canada <i>(tel)</i> 1 877 894 4414 <i>(fax)</i> (905) 282-6495
Europe <i>(tel)</i> (+31) 20 547 2323 <i>(fax)</i> (+31) 20 547 2390	Australia <i>(tel)</i> 1 800 629 485 <i>(fax)</i> (+61) 3 9210 5947	New Zealand <i>(tel)</i> 0 800 738 378 <i>(fax)</i> (+64) 4 495 8950
Japan <i>(tel)</i> (+81) 426 56 7832 <i>(fax)</i> (+81) 426 56 7840	Singapore <i>(tel)</i> 1 800 375 8100 <i>(fax)</i> (65) 836 0252	Malaysia <i>(tel)</i> 1 800 828 848 <i>(fax)</i> 1 800 801 664
India <i>(tel)</i> 1 600 11 2929 <i>(fax)</i> 000 800 650 1101	Hong Kong <i>(tel)</i> 800 930 871 <i>(fax)</i> (852) 2506 9233	Taiwan <i>(tel)</i> 0800 047 866 <i>(fax)</i> (886) 2 25456723
Philippines <i>(tel)</i> (632) 8426802 <i>(tel)</i> (PLDT subscriber only) 1 800 16510170 <i>(fax)</i> (632) 8426809 <i>(fax)</i> (PLDT subscriber only) 1 800 16510288	Thailand <i>(tel)</i> (outside Bangkok) (088) 226 008 <i>(tel)</i> (within Bangkok) (662) 661 3999 <i>(fax)</i> (66) 1 661 3714	People's Republic of China <i>(tel)</i> (preferred) 800 810 0189 <i>(tel)</i> (alternate) 10800 650 0021 <i>(fax)</i> 10800 650 0121

Installation Procedure for the Upgrade Kit

The network analyzer must be in proper working condition prior to installing this option. Any necessary repairs must be made before proceeding with this installation.

WARNING **This installation requires the removal of the analyzer's protective outer covers. The analyzer must be powered down and disconnected from the mains supply before performing this procedure.**

Electrostatic Discharge Protection

Protection against electrostatic discharge (ESD) is essential while removing or connecting cables or assemblies within the network analyzer.

Static electricity can build up on your body and can easily damage sensitive internal circuit elements when discharged. Static discharges too small to be felt can cause permanent damage. To prevent damage to the instrument:

- *always* wear a grounded wrist strap having a 1 M Ω resistor in series with it when handling components and assemblies.
- *always* use a grounded, conductive table mat while working on the instrument.
- *always* wear a heel strap when working in an area with a conductive floor. If you are uncertain about the conductivity of your floor, wear a heel strap.

Figure 1 shows a typical ESD protection setup using a grounded mat and wrist strap. Refer to “Tools and Equipment Required for the Installation” on page 7 for part numbers.

Figure 1 **ESD Protection Setup**

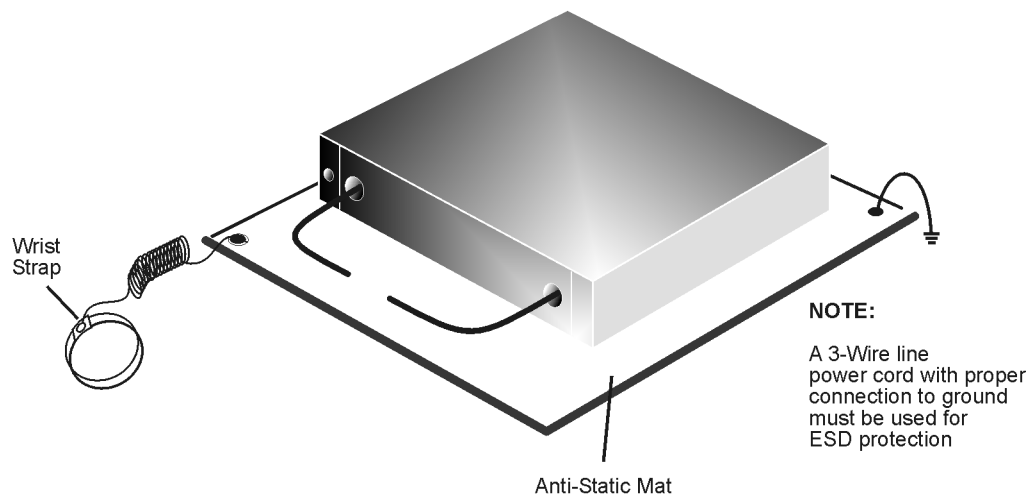

ku310b

Overview of the Installation Procedure

Note that step 2 is necessary only for the E8356A network analyzer because it requires a new A12 source assembly.

1. Verify the serial and option numbers of the analyzer.
2. Replace the A12 source assembly (E8356A only).
3. Enter the new model number.
4. Verify that the new model number is shown correctly.
5. Replace the model number nameplate on the front panel.
6. Perform source and receiver calibration adjustments.

Tools and Equipment Required for the Installation

Description	Model/Part Number
Tools for A12 Source Assembly Replacement (E8356A Only)	
T-10 TORX driver (set to 9 in-lbs)	N/A
T-20 TORX driver (set to 21 in-lbs)	N/A
5/16-inch open-end torque wrench (set to 10 in-lb)	N/A
ESD Equipment	
ESD grounding wrist strap	9300-1367
5 ft grounding cord for wrist strap	9300-0980
2 x 4 ft conductive table mat and 15 ft grounding wire	9300-0797
ESD heel strap (for use with conductive floors)	9300-1308
Test Equipment for Calibration Adjustments	
Power meter	E4419B
Power sensor (100 kHz–4.2 GHz)	8482A
Power sensor (10 MHz–18 GHz)	E4412A
Type-N adapter (female-to-female)	1250-0777
Type-N RF cable	N6314A

Step 1. Verify the Serial and Option Numbers of the Analyzer

Refer to the License Key Certificate supplied with the kit:

- Verify that the analyzer's serial number matches the serial number on the certificate.
- Verify that the option number on the certificate is either 1F6 (for a 6 GHz upgrade) or 1F9 (for a 9 GHz upgrade).

If either the serial number or the option number does not match the expected results, you will not be able to install the option. If this is the case, contact Agilent for assistance. Refer to [“Getting Assistance from Agilent” on page 5](#).

Step 2. Replace the A12 Source Assembly (E8356A Only)

This step is necessary only for the E8356A network analyzer. If installing an upgrade kit for the E8357A network analyzer, proceed to Step 3.

Remove the Outer and Inner Covers from the Analyzer

Refer to [Figure 2](#) for this procedure.

Remove the Outer Cover

CAUTION This procedure is best performed with the analyzer resting on its front handles in the vertical position. *Do not place the analyzer on its front panel without the handles.* This will damage the front panel assemblies.

1. Disconnect the power cord (if it has not already been disconnected).
2. With a T-20 TORX driver, remove the strap handles (item ①) by loosening the screws (item ②) on both ends until the handle is free of the analyzer.
3. With a T-20 TORX driver, remove the four rear panel feet (item ③) by removing the center screws (item ④).
4. Slide the four bottom feet (item ⑤) off the cover.
5. Slide the cover off of the frame.

Remove the Inner Cover

1. With a T-10 TORX driver, remove the 15 screws (item ⑥).
2. Lift off the cover.

Figure 2 Outer and Inner Cover Removal

Outer Cover Removal

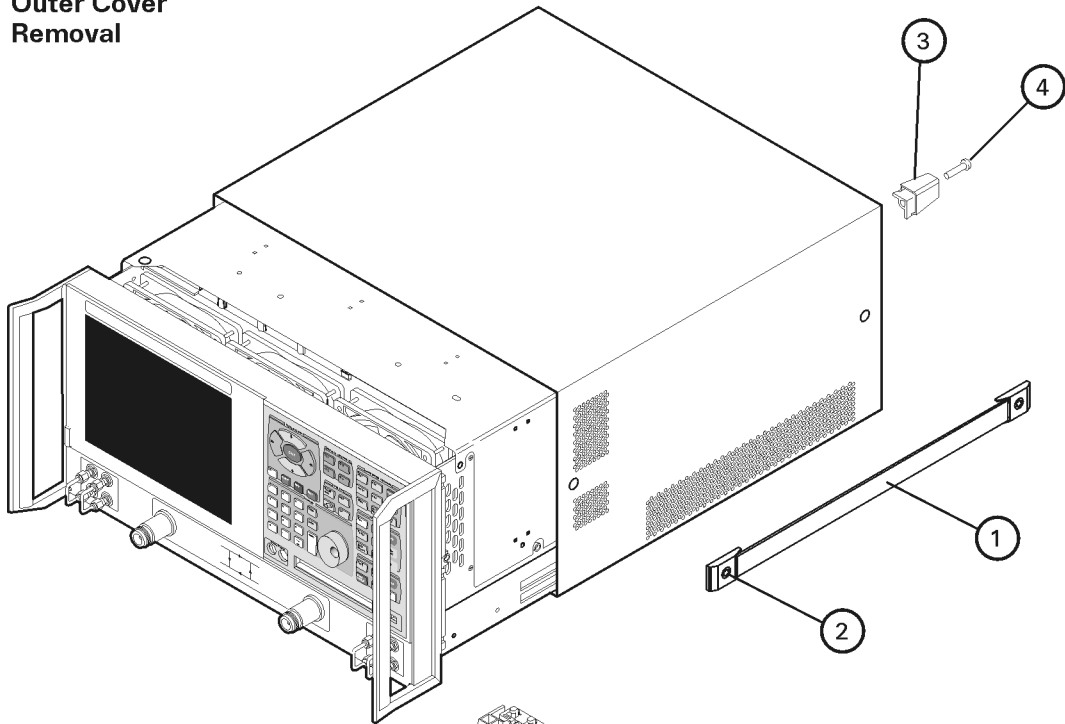

Inner Cover Removal

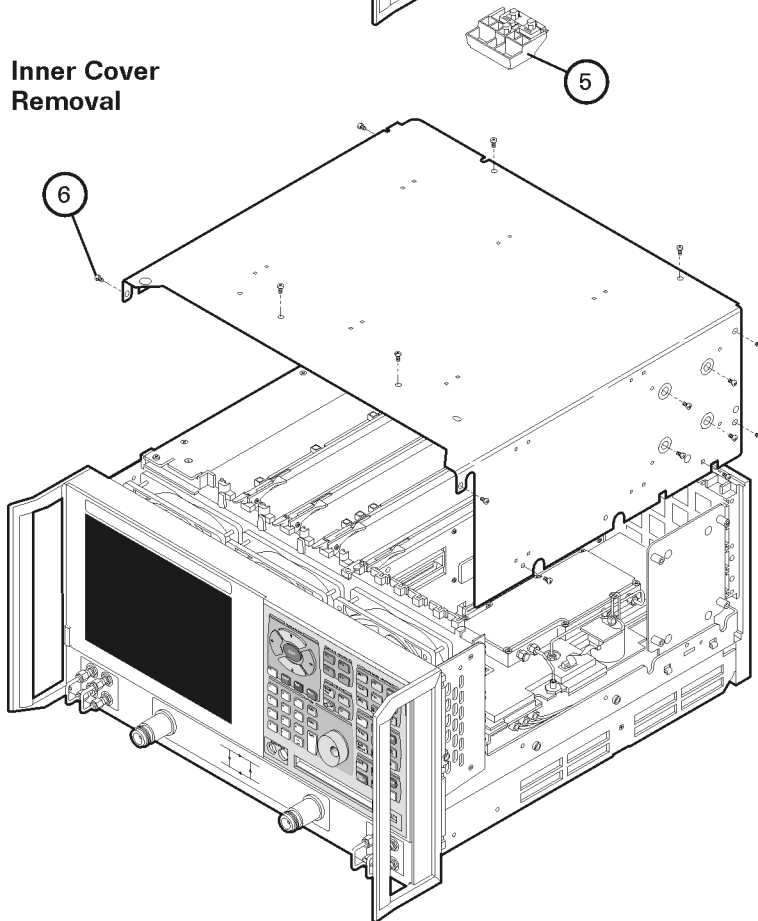

sc857a

Replace the A12 Source Assembly

Refer to [Figure 3](#) for this step.

1. Place the A31 hard disk drive assembly in the service position.
 - a. With a T-10 TORX driver, remove the mounting screw (item ①).
 - b. Move the HDDA to the outside of the analyzer and slide the HDDA bracket feet into the slots on the frame to the horizontal position. This is the service position.

Figure 3 Placing the A31 HDDA in the Service Position

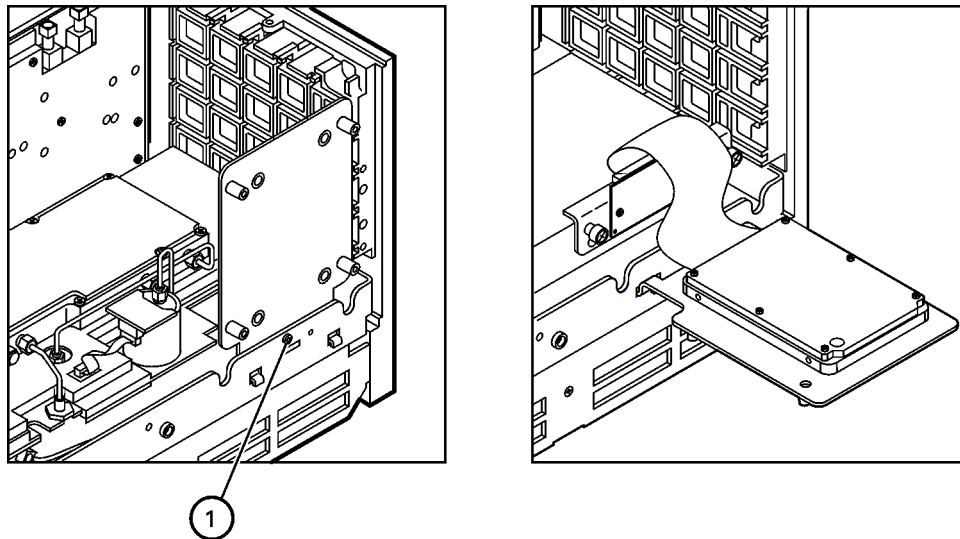

dc801o

Refer to [Figure 4](#) for the following steps.

2. Disconnect the three flexible cables (item ①) from the A12 source assembly being careful to note their locations for reconnection later.

CAUTION Be careful not to damage the center pins of the semirigid cables. Some flexing of the cables is necessary to remove the assembly. Do not over-bend the semirigid cables.

3. With a 5/16-in torque wrench, disconnect the semirigid cable (item ②) from the bottom of the A12 source assembly.

CAUTION To avoid damage to the semirigid cable (item ②), pull down on the cable from the bottom of the analyzer to move it away while sliding out the A12 source assembly. The cable has some spring to it and the RF pin could be damaged by the A12 source assembly.

4. Slide the A12 source assembly out of the analyzer.
5. Slide the new A12 source assembly into the analyzer being careful not to damage the semirigid cables. Refer to the CAUTIONs above.

6. With a 5/16-in torque wrench, reconnect the semirigid cable (item ②) to the bottom of the A12 source assembly.

7. Reconnect the three flexible cables (item ①) to the A12 source assembly.

Refer to [Figure 3](#) for the following steps.

8. Reinstall the A31 hard disk drive assembly into its original position.

9. With a T-10 TORX driver, replace the mounting screw (item ①)

Figure 4 A12 Source Assembly Replacement

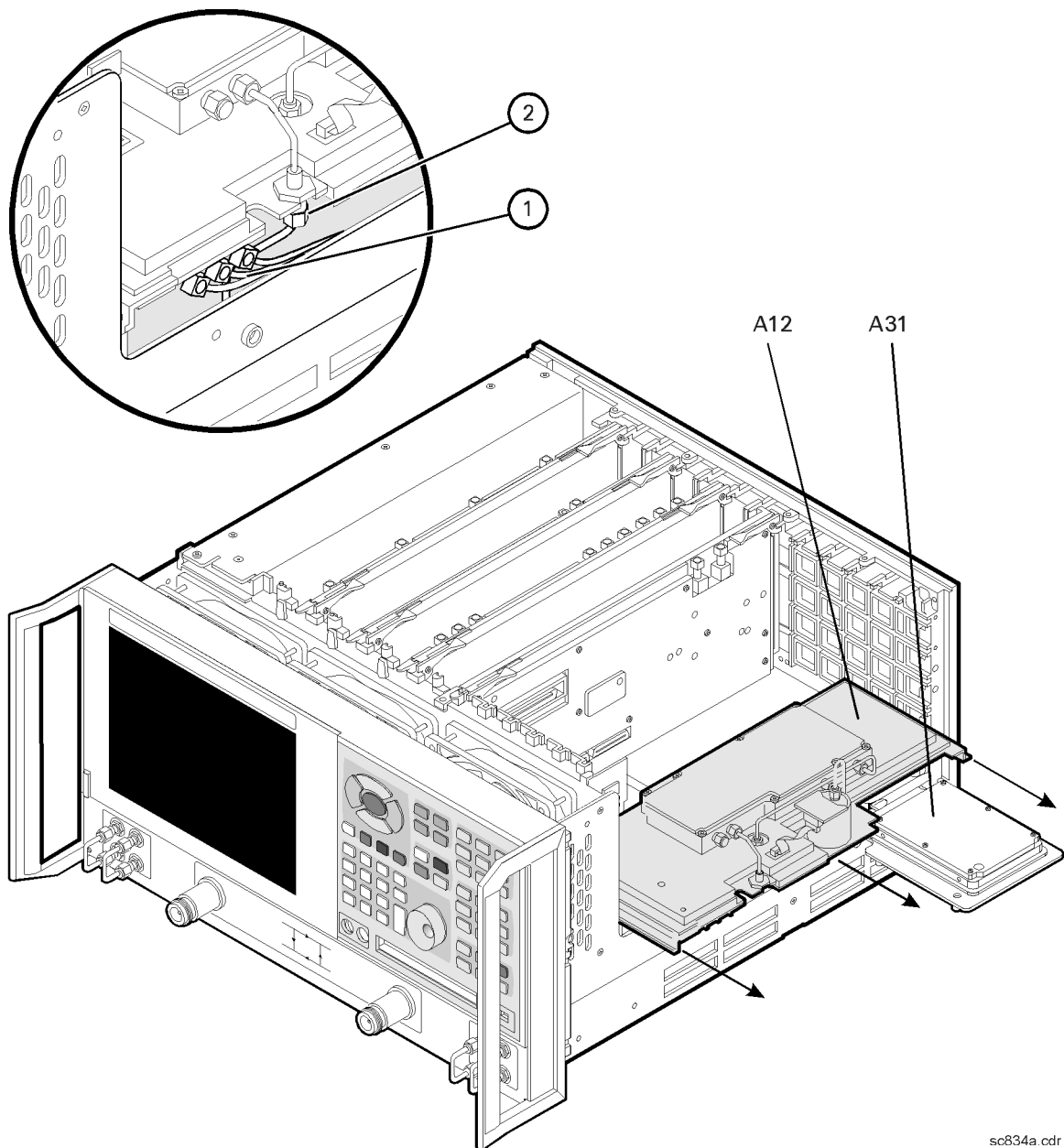

sc834a.cdr

Reinstall the Inner and Outer Covers

Refer to [Figure 5](#) for this procedure.

Reinstall the Inner Cover

1. Place the inner cover on the analyzer. There are two alignment pins on the front frame that must be aligned with holes in the cover.
2. With a T-10 TORX driver, install the 15 screws (item ①).

Reinstall the Outer Cover

CAUTION This procedure is best performed with the analyzer resting on its front handles in the vertical position. *Do not place the analyzer on its front panel without the handles.* This will damage the front panel assemblies.

1. Slide the cover onto the frame.
2. With a T-20 TORX driver, install the four rear panel feet (item ②) by installing the center screws (item ③).
3. Slide the four bottom feet (item ④) onto the cover.
4. With a T-20 TORX driver, install the strap handles (item ⑤) by tightening the screws (item ⑥) on both ends.

Figure 5 Inner and Outer Cover Reinstallation

Inner Cover Installation

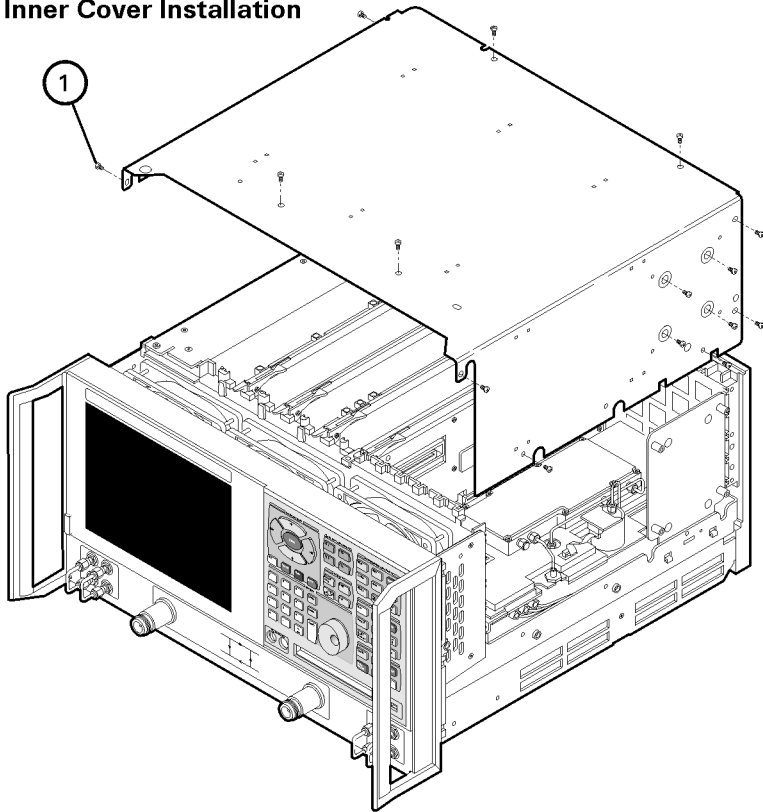

Outer Cover Installation

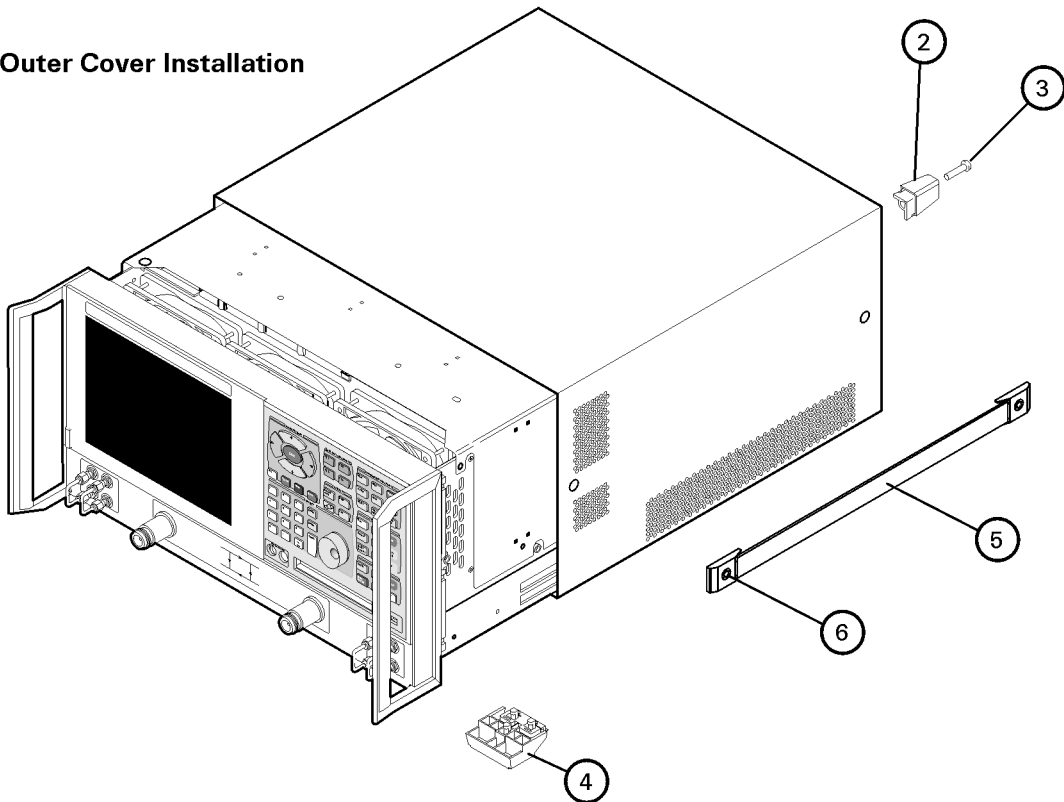

dc802a

Step 3. Enter the New Model Number

Procedure Requirements

- The analyzer must be powered up and operating to perform this procedure.
- The Network Analyzer program must be running.
- A keyboard is required for this procedure.
- A mouse is recommended for this procedure but is not required.

Mouse Procedure

1. On the analyzer's **System** menu, point to **Service**, then click **Option Enable**.
2. Click **Repair**.
3. Check **Model shown is incorrect!**, then click **Begin Repair**.
4. In the **Model Change** box, select the appropriate new model number: **E8357A** (for the 6 GHz upgrade) or **E8358A** (for the 9 GHz upgrade).
5. Using the keyboard, enter the keyword in the box provided. The keyword is printed on the License Key Certificate. Enter this keyword *exactly* as it is printed on the certificate.
6. Click **Enter Model**.
7. Verify that the new model number displayed is correct, then click **YES**. If it is not correct, click **NO** and repeat the repair.
8. When the installation is complete, click **Exit**.

Front Panel Keys Procedure

1. In the **COMMAND** block, press **Menu/Dialog**.
2. In the **NAVIGATION** block, press the right tab and arrow keys to move over to the **System** menu and down to the **Service** selection. Press the right tab to display the extended menu and the arrows to select **Option Enable**. Press **Click**.
3. Press **Menu/Dialog**, then press **R** on the keyboard to select **Repair**.
4. Tab to **Model shown is incorrect!**, then press **Click**.
5. Tab to the **Model Change** box, then use the arrows to select the appropriate new model number: **E8357A** (for the 6 GHz upgrade) or **E8358A** (for the 9 GHz upgrade).
6. Tab to the **Keyword** box and, using the keyboard, enter the keyword. The keyword is printed on the License Key Certificate. Enter this keyword *exactly* as it is printed on the certificate.
7. Tab to **Enter Model**, then press **Click**.
8. Verify that the new model number displayed is correct, then tab to **Yes** and press **Click**. If it is not correct, tab to **NO**, press **Click**, and repeat the repair.
9. When the installation is complete, Tab to **Exit**, then press **Click**.

Step 4. Verify that the New Model Number Is Shown Correctly

Procedure Requirements

- The analyzer must be powered up and operating to perform this procedure.
- The Network Analyzer program must be running.
- A mouse is recommended for this procedure but is not required.

Mouse Procedure

1. On the analyzer's **Help** menu, click **About Network Analyzer**.
2. Verify that the new model number is shown correctly in the display. Click **OK**.
3. On the analyzer front panel, press **Preset**. Verify that the full frequency range of the analyzer is correct.

Front Panel Keys Procedure

1. In the **COMMAND** block, press **Menu/Dialog**.
2. In the **NAVIGATION** block, press the right tab and arrow keys to move over to the **Help** menu, and down to the **About Network Analyzer** selection. Press **Click**.
3. Verify that the new model number is shown correctly, then press **Click**.
4. On the analyzer front panel, press **Preset**. Verify that the full frequency range of the analyzer is correct.

Step 5. Replace the Model Number Nameplate on the Front Panel

Refer to [Figure 6](#) for this procedure.

Remove the Old Nameplate

1. Using a sharp object such as a knife blade, lift one end of the old nameplate (item ①). Be careful not to scratch the painted surface.
2. Using your fingers, pull the nameplate completely off of the front panel and discard it.
3. If any adhesive remains on the front panel surface, it can be removed by rubbing it with your finger. Do not use a sharp object to remove this adhesive. If necessary, the surface can be cleaned with isopropol alcohol.

Install the New Nameplate

1. Remove the protective backing from the new nameplate to expose the adhesive. Avoid touching the adhesive with your fingers as this may affect its ability to adhere to the front panel surface.
2. *Loosely* align the new nameplate over the recess in the front panel and apply lightly.
3. Once the overlay is properly aligned, press it firmly onto the surface to secure it.

Figure 6 Model Number Nameplate Replacement

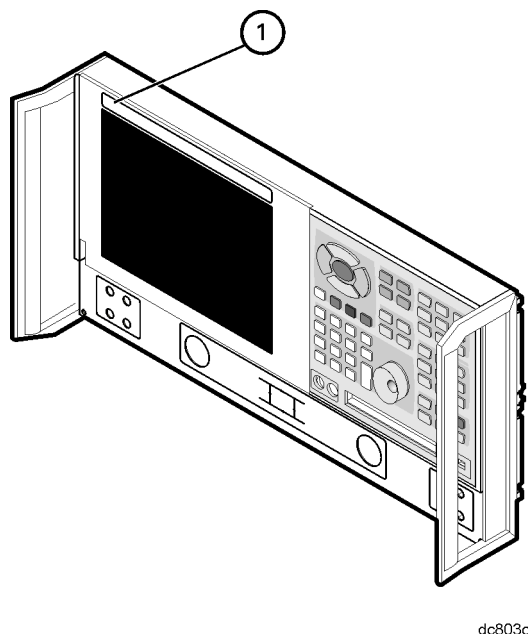

dc803o

Step 6. Perform Source and Receiver Calibration Adjustments

The following adjustments must be made due to the change in the full frequency range of the analyzer.

Source Calibration Adjustment

The source calibration is used to adjust your network analyzer for a flat source power across its full frequency range. The differences between Port 1 and Port 2 are negligible; therefore, a Port 2 adjustment is not required.

1. Connect the equipment as shown in [Figure 7](#). Connect a GPIB cable between the network analyzer and the power meter.

Figure 7 Setup for the Source Calibration Adjustment

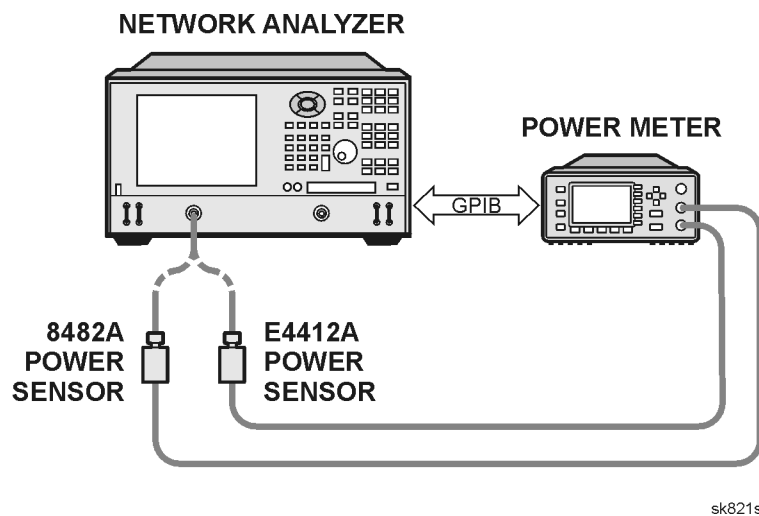

2. On the **System** menu, point to **Service, Adjustments**, then click **Source Calibration**.
3. Ensure the GPIB settings are correct.
4. Click **Calibrate**, then follow the instructions as they are displayed.

Receiver Calibration Adjustment

The receiver calibration is used to adjust the network analyzer receivers for a flat response across its full frequency range. A power meter is connected to Port 1, as shown in [Figure 8](#), to establish a reference for flatness. A signal from Port 1, as shown in [Figure 9](#), is used to adjust the “B” receiver at Port 2. The adjustment is repeated using a signal from Port 2 to adjust the “A” receiver at Port 1.

1. Connect the equipment as shown in [Figure 8](#). Connect a GPIB cable between the network analyzer and the power meter.

Figure 8 Setup for the Receiver Calibration Adjustment

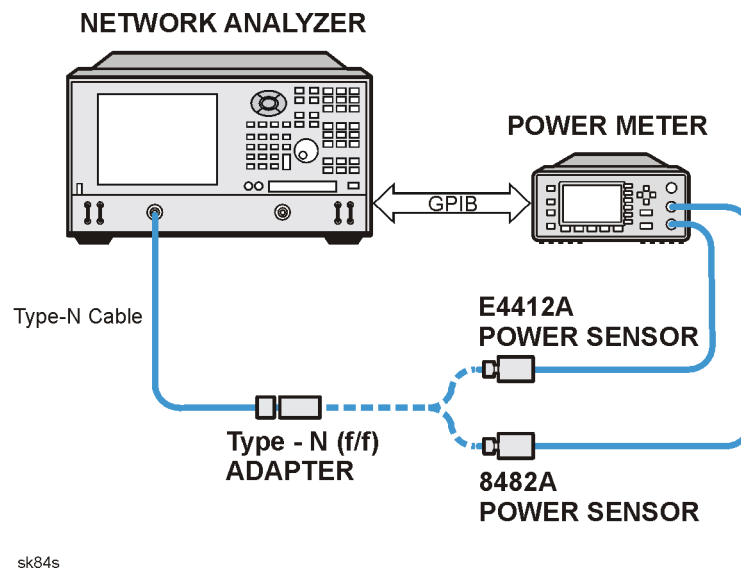
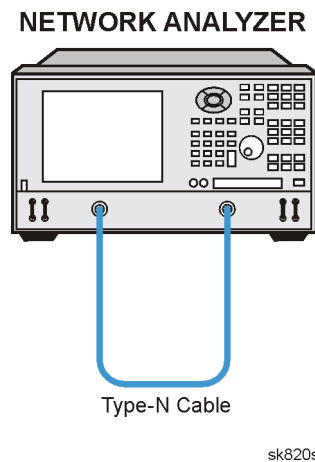

Figure 9 Setup for the Receiver Calibration Adjustment of Port 2



2. On the **System** menu, point to **Service, Adjustments**, then click **Receiver Calibration**.
3. Ensure the GPIB settings are correct.
4. Click **Calibrate**, then follow the instructions as they are displayed.

Performance Tests and System Verification

The analyzer should now operate and phase lock over its entire frequency range.

If you experience difficulty with the basic functioning of the analyzer, contact Agilent. Refer to [“Getting Assistance from Agilent” on page 5](#).

Although the analyzer functions, its performance relative to its specifications has not been verified for the additional frequency range enabled by this upgrade.

It is recommended that a full instrument calibration be performed using the N2721A performance test software.

If the testing of the analyzer’s full range of specifications is not required, a system verification can be performed.

Refer to the analyzer’s service guide for information on performance tests and system verification.